



**Copyright © 2009 IBASE Technology INC. All Rights Reserved.**

No part of this manual, including the products and software described in it, may be reproduced, transmitted, transcribed, stored in a retrieval system, or translated into any language in any form or by any means, except documentation kept by the purchaser for backup purposes, without the express written permission of IBASE Technology INC. ("IBASE").

Products and corporate names mentioned in this manual may or may not be registered trademarks or copyrights of their respective companies, and are used for identification purposes only. All trademarks are the property of their respective owners.

Every effort has been made to ensure that the contents of this manual are correct and up to date. However, the manufacturer makes no guarantee regarding the accuracy of its contents, and reserves the right to make changes without prior notice.

# Table of Contents

<b><i>Acknowledgments</i></b> .....	<b>6</b>
<b><i>Accessories</i></b> .....	<b>7</b>
<b><i>Components</i></b> .....	<b>8</b>
I/O View .....	8
<b><i>Specification</i></b> .....	<b>10</b>
<b><i>Mounting SI-24 to the Wall</i></b> .....	<b>11</b>
Wall mounting requirements .....	11
Selecting the location .....	12
<b><i>Exploded view of the SI-24 assembly</i></b> .....	<b>13</b>
Parts description .....	13
<b><i>Installation</i></b> .....	<b>14</b>
Installing the memory .....	14
Setting Jumper .....	15
<b><i>BIOS Setup</i></b> .....	<b>17</b>
BIOS Introduction .....	17
BIOS Setup .....	17
<b><i>Driver Installation</i></b> .....	<b>36</b>
<b><i>Appendix</i></b> .....	<b>42</b>
I/O Port Address Map .....	42
Interrupt Request Lines (IRQ).....	43
Watchdog Timer Configuration .....	44

## **Safety Information**

Your SI-24 is designed and tested to meet the latest standards of safety for information technology equipment. However, to ensure your safety, it is important that you read the following safety instructions.

### ***Setting up your system***

- Read and follow all instructions in the documentation before you operate your system.
- Do not use this product near water.
- Set up the system on a stable surface or secure on wall with the provided rail. Do not secure the system on any unstable plane or without the rail.
- Do not place this product on an unstable cart, stand, or table. The product may fall, causing serious damage to the product.
- Slots and openings on the chassis are for ventilation. Do not block or cover these openings. Make sure you leave plenty of space around the system for ventilation. Never insert objects of any kind into the ventilation openings.
- This system should be operated from the type of power indicated on the marking label. If you are not sure of the type of power available, consult your dealer or local power company.
- Use this product in environments with ambient temperatures between 0°C and 45°C.
- If you use an extension cord, make sure that the total ampere rating of the devices plugged into the extension cord does not exceed its ampere rating.

### ***Care during use***

- Do not walk on the power cord or allow anything to rest on it.
- Do not spill water or any other liquids on your system.
- When the system is turned off, a small amount of electrical current still flows. Always unplug all power, and network cables from the power outlets before cleaning the system.
- If you encounter the following technical problems with the product, unplug the power cord and contact a qualified service technician or your retailer.
  - The power cord or plug is damaged.
  - Liquid has been spilled into the system.
  - The system does not function properly even if you follow the operating instructions.

- The system was dropped or the cabinet is damaged.

### **Lithium-Ion Battery Warning**

**CAUTION:** Danger of explosion if battery is incorrectly replaced. Replace only with the same or equivalent type recommended by the manufacturer. Dispose of used batteries according to the manufacturer's instructions.



### **NO DISASSEMBLY**

The warranty does not apply to the products that have been disassembled by users

## Acknowledgments

- Award is a registered trademark of Award Software International, Inc.
- PS/2 is a trademark of International Business Machines Corporation.
- AMD Sempron™ 200U/210U is registered trademarks of AMD Corporation.
- Microsoft Windows is a registered trademark of Microsoft Corporation.
- Winbond is a registered trademark of Winbond Electronics Corporation.
- All other product names or trademarks are properties of their respective owners.

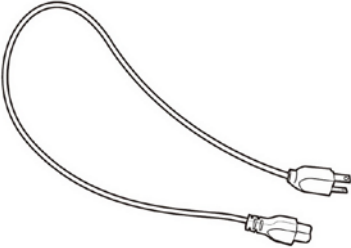
## Accessories

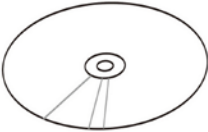
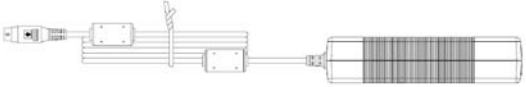
 A power cord with a standard AC power plug on one end and a smaller, specialized connector on the other.	 A small, rectangular booklet with the words "User Manual" printed on its cover.
a. Power Cord x 1	b. System Manual x 1
 A standard compact disc (CD) with its reflective surface and a central hole.	 A power brick, which is a small, rectangular external power supply unit with a power cord and a connector.
c. Driver CD x 1	d. Power Brick x 1

# Components

## I/O View

Refer to the diagram below to identify the components on this side of the system.

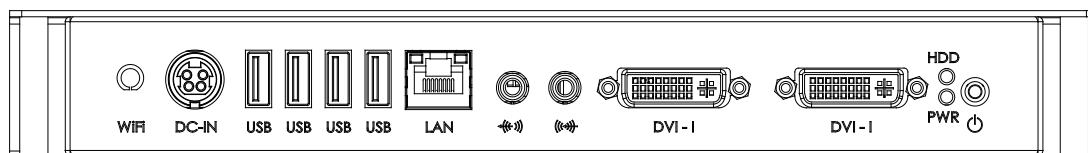

The power switch allows powering ON and OFF the system.

### HDD

The hard disk LED blinks when data is being written into or read from the hard disk drive.

### PWR

The power LED illuminated when system been power on.

### DVI-I

The Digital Visual Interface (DVI) port supports a high quality VGA-compatible device such as a monitor or projector to allow viewing on a larger external display. This connector contain digital and analog video signal, you can use specified cable to obtain standard analog VGA output.



The stereo headphone jack (3.5mm) is used to connect the audio signal into system to record or bypass it to storage or LINE OUT.



The stereo audio jack (3.5mm) is used to connect the system's audio out signal to amplified speakers or headphones.

**LAN**

The eight-pin RJ-45 LAN port supports a standard Ethernet cable for connection to a local network.

**USB**

The USB (Universal Serial Bus) port is compatible with USB devices such as keyboards, mouse devices, cameras, and hard disk drives. USB allows many devices to run simultaneously on a single computer, with some peripheral acting as additional plug-in sites or hubs.

**DC IN**

The supplied power adapter converts AC power to DC power for use with this jack. Power supplied through this jack supplies power to the system. To prevent damage to the system, always use the supplied power adapter.

**WiFi**

The jack is used to connect the off-the-shelf wireless antenna to enhance wireless signal reception.

## Specification

<b>System Mainboard</b>	IB-824
<b>Construction</b>	Aluminum
<b>Chassis Color</b>	Black / White
<b>Storage</b>	2.5" 80GB SATA HDD x 1
<b>Mounting</b>	Desktop or wall mount
<b>Dimensions</b>	270(W) x 37(H) x 182(D)mm (10.63" x 1.45" x 7.16")
<b>Power Supply</b>	80W DC adapter
<b>Operating Temperature</b>	0°C ~ 45°C (32°F ~ 113°F)
<b>Storage Temperature</b>	-20°C ~ 80°C
<b>Relative Humidity</b>	5~95% @45°C (non-condensing)
<b>Vibration</b>	HDD: 0.25grms/5~500Hz random operation
<b>Shock</b>	HDD: 15grms peak acceleration (11 msec duration)
<b>RoHS</b>	Available

· This specification is subject to change without prior notice.

## Mounting SI-24 to the Wall

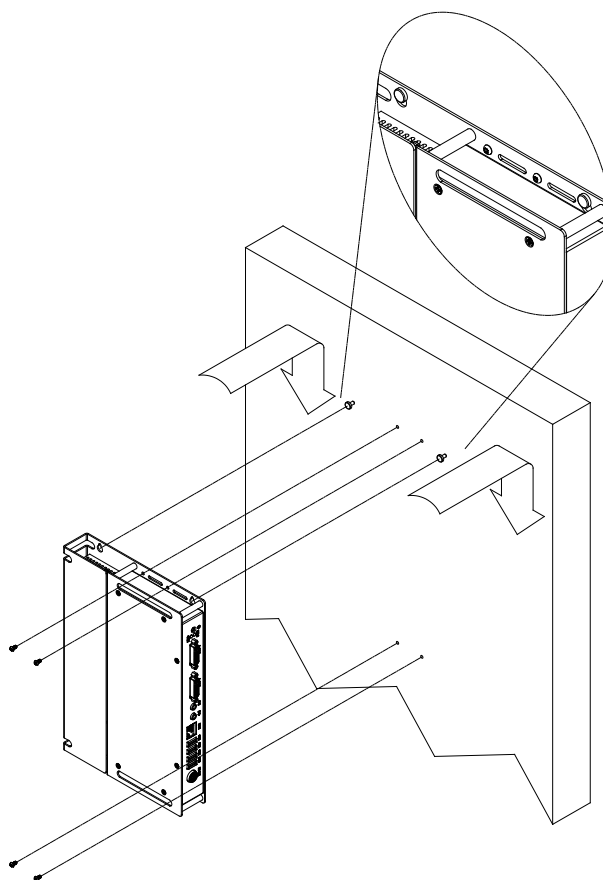

You can install SI-24 on wood, drywall surface over studs, or a solid concrete or metal plane directly. Ensure the installer uses at least four M3 length 8mm screws to secure the system on wall. ***Six M3 length 8mm screws are recommended to secure the system on wall.***

Fasteners are not included with the unit, and must be supplied by the installer. The types of fasteners required are dependent on the type of wall construction. Choose fasteners that are rated either "Medium Duty" or "Heavy Duty." To assure proper fastener selection and installation, follow the fastener manufacturer's recommendations.

### Wall mounting requirements

**Note:** Before mounting the system on wall, ensure that you are following all applicable building and electric codes.

When mounting, ensure that you have enough room for power and signal cable routing. And have good ventilation for power adapter. The method of mounting must be able to support weight of the SI-24 plus the suspend weight of all the cables to be attached to the system. Use the following methods for mounting your system:

#### **Mounting to hollow walls**

- **Method 1: Wood surface** – A minimum wood thickness – 38mm (1.5in.) by 25.4 cm (10in.) – of high, construction – grade wood is recommended.  
**Note:** This method provides the most reliable attachment of the unit with little risk that the unit will come loose or require ongoing maintenance.
- **Method 2: Drywall walls** - Drywall over wood studs is acceptable.

**Mounting to a solid concrete or brick wall** - Mounts on a flat smooth surface.

#### **Selecting the location**

Plan the mounting location thoroughly. Locations such as walkway areas, hallways, and crowded areas are not recommended. Mount the unit to a flat, sturdy, structurally sound column or wall surface.

The best mounting surface is a standard countertop, cabinet, table, or other structure that is minimally the width and length of the unit. This recommendation reduces the risk that someone may accidentally walk into and damage the device. Local laws governing the safety of individuals might require this type of consideration.

## Exploded view of the SI-24 assembly

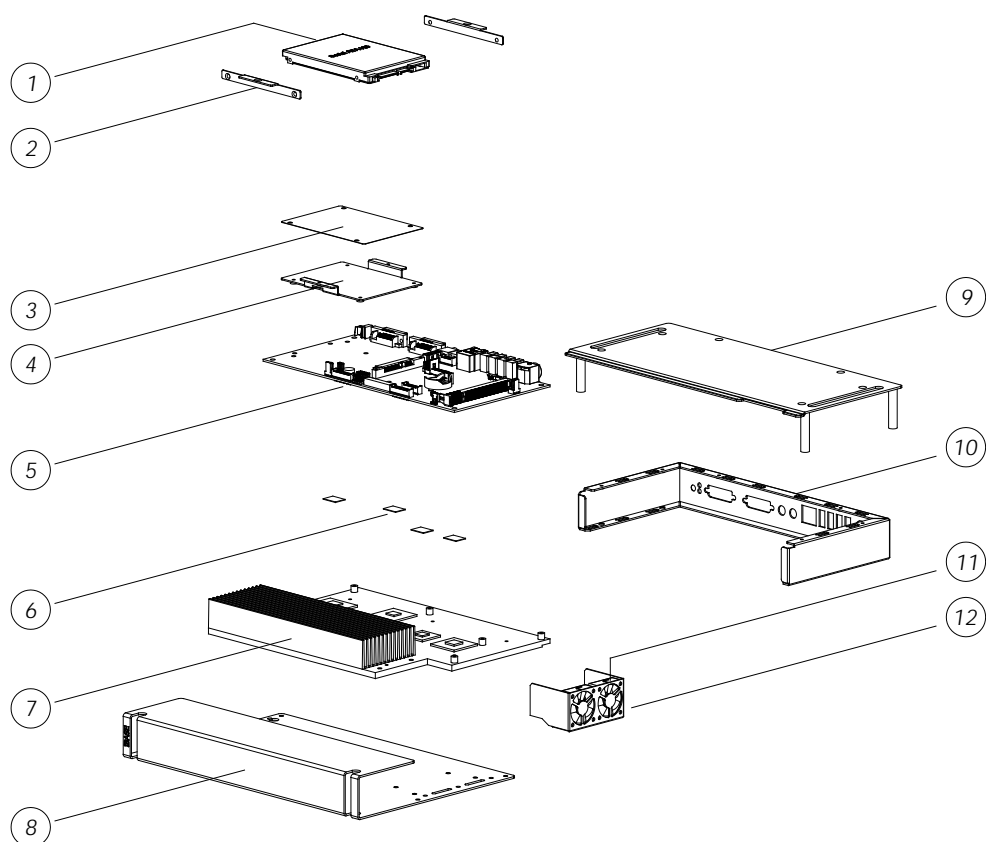

### Parts description

Part NO.	Description	Part NO.	Description
1	HDD	2	HDD side bracket
3	HDD Mylar	4	HDD tray bracket
5	M/B IB824	6	Thermal Interface Material
7	Heat sink	8	Bottom chassis
9	Top cover	10	I/O wall
11	System FAN	12	System FAN bracket

# Installation

## Installing the memory

The IB824 board supports one DDR2 memory socket that can support up to 2GB memory size, DDR2 400/533/667 (w/o ECC function).

### Installing and Removing Memory Modules

To install the DDR2 modules, locate the memory slot on the board and perform the following steps:

1. Hold the DDR2 module so that the key of the DDR2 module aligns with that on the memory slot. Insert the module into the socket at a slight angle (approximately 30 degrees). Note that the socket and module are both keyed, which means that the module can be installed only in one direction.
2. To seat the memory module into the socket, apply firm and even pressure to each end of the module until you feel it slip down into the socket.
3. With the module properly seated in the socket, rotate the module downward. Continue pressing downward until the clips at each end lock into position.
4. To remove the DDR2 module, press the clips with both hands.

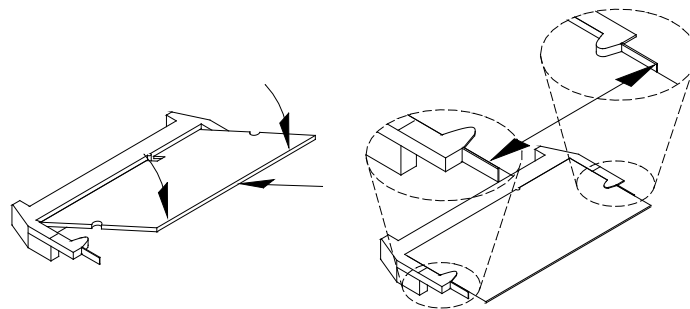



## Setting Jumper

Jumpers are used on IB824 to select various settings and features according to your needs and applications. Contact your supplier if you have doubts about the best configuration for your needs. The following lists the connectors on IB824 and their respective functions

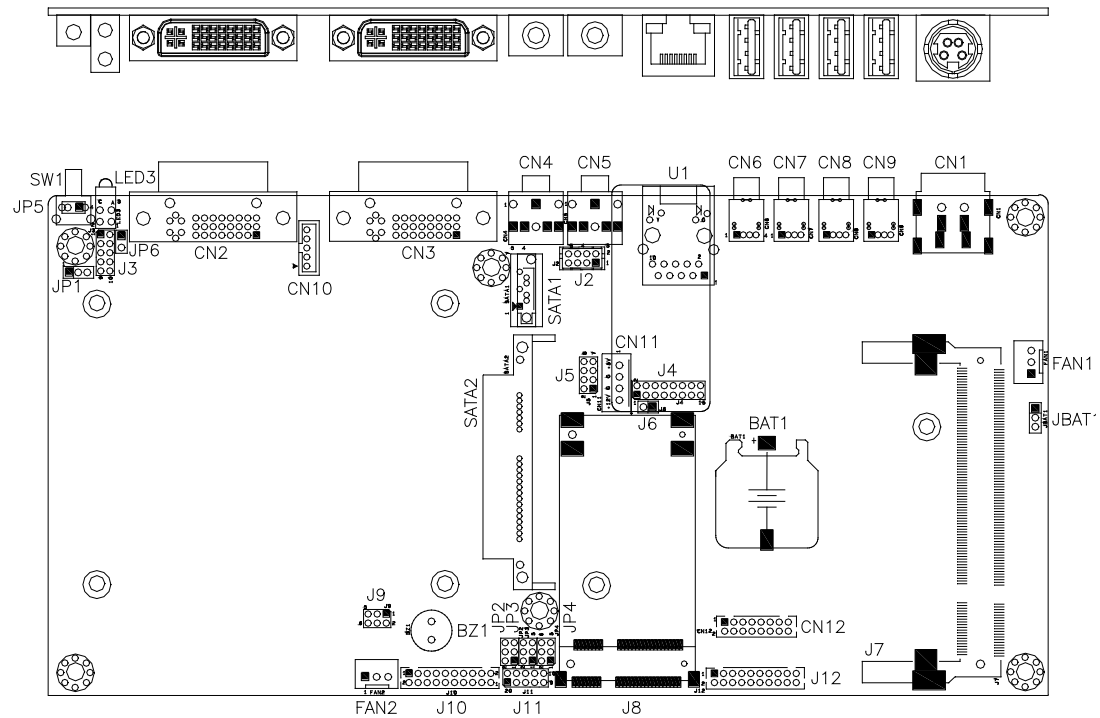
### Jumper Locations on IB824



### JP1: ATX or AT Power Selection

JP1	ATX Power
	ATX
	AT

### JP2, JP3, JP4: RS232/422/485 (COM2) Selection

COM1 is fixed for RS-232 use only. COM2 is selectable for RS232, RS-422 and RS-485. The following describes the settings for COM2.

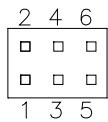

COM2 Function	RS-232	RS-422	RS-485
Jumper Setting (pin closed)	JP4: 1-2 JP2: 3-5 & 4-6 JP3: 3-5 & 4-6	JP4: 3-4 JP2: 1-3 & 2-4 JP3: 1-3 & 2-4	JP4: 5-6 JP2: 1-3 & 2-4 JP3: 1-3 & 2-4

- COM2 is jumper selectable for RS-232, RS-422 and RS-485.

Pin #	Signal Name		
	RS-232	RS-422	RS-485
11	DCD	TX-	DATA-
13	RX	TX+	DATA+
15	TX	RX+	NC
17	DTR	RX-	NC
19	Ground	Ground	Ground
12	DSR	RTS-	NC
14	RTS	RTS+	NC
16	CTS	CTS+	NC
18	RI	CTS-	NC
20	NC	NC	NC

### JBAT1: Clear CMOS Setting

JBAT1	Setting
 1 2 3	Normal
 1 2 3	Clear CMOS

## BIOS Setup

This chapter describes the different settings available in the Award BIOS that comes with the board.

### BIOS Introduction

The Award BIOS (Basic Input / Output System) installed in your computer system's ROM supports various processors. The BIOS provides critical low-level support for a standard device such as disk drives, serial ports and parallel ports. It also adds virus and password protection as well as special support for detailed fine-tuning of the chipset controlling the entire system.

### BIOS Setup

The Award BIOS provides a Setup utility program for specifying the system configurations and settings. The BIOS ROM of the system stores the Setup utility. When you turn on the computer, the Award BIOS is immediately activated. Pressing the <Del> key immediately allows you to enter the Setup utility. If you are a little bit late pressing the <Del> key, POST (Power On Self Test) will continue with its test routines, thus preventing you from invoking the Setup. If you still wish to enter Setup, restart the system by pressing the "Reset" button or simultaneously pressing the <Ctrl>, <Alt> and <Delete> keys. You can also restart by turning the system Off and back On again. The following message will appear on the screen:

```
Press <DEL> to Enter Setup
```

In general, you press the arrow keys to highlight items, <Enter> to select, the <PgUp> and <PgDn> keys to change entries, <F1> for help and <Esc> to quit.

When you enter the Setup utility, the Main Menu screen will appear on the screen. The Main Menu allows you to select from various setup functions and exit choices.

Standard CMOS Features	Frequency/Voltage Control
Advanced BIOS Features	Load Fail-Safe Defaults
Advanced Chipset Features	Load Optimized Defaults
Integrated Peripherals	Set Supervisor Password
Power Management Setup	Set User Password
PnP/PCI Configurations	Save & Exit Setup
PC Health Status	Exit Without Saving
ESC : Quit	↑ ↓ → ← : Select Item
F10 : Save & Exit Setup	
Time, Date, Hard Disk Type...	

The section below the setup items of the Main Menu displays the control keys for this menu. At the bottom of the Main Menu just below the control keys section, there is another section, which displays information on the currently highlighted item in the list.

**Note:** *If the system cannot boot after making and saving system changes with Setup, the Award BIOS supports an override to the CMOS settings that resets your system to its default.*

**Warning:** *It is strongly recommended that you avoid making any changes to the chipset defaults. These defaults have been carefully chosen by both Award and your system manufacturer to provide the absolute maximum performance and reliability. Changing the defaults could cause the system to become unstable and crash in some cases.*

## Standard CMOS Setup

“Standard CMOS Setup” choice allows you to record some basic hardware configurations in your computer system and set the system clock and error handling. If the motherboard is already installed in a working system, you will not need to select this option. You will need to run the Standard CMOS option, however, if you change your system hardware configurations, the onboard battery fails, or the configuration stored in the CMOS memory was lost or damaged.

Phoenix - AwardBIOS CMOS Setup Utility

Standard CMOS Features

Date (mm:dd:yy)	Wed, Apr 28, 2007	Item Help
Time (hh:mm:ss)	00 : 00 : 00	Menu Level >
		Change the day, month, Year and century
Halt On	No Errors	
Base Memory	640K	
Extended Memory	129024K	
Total Memory	130048K	

At the bottom of the menu are the control keys for use on this menu. If you need any help in each item field, you can press the <F1> key. It will display the relevant information to help you. The memory display at the lower right-hand side of the menu is read-only. It will adjust automatically according to the memory changed. The following describes each item of this menu.

### Date

To set the date, highlight the “Date” field and use the PageUp / PageDown or +/- key to set the current time.

The date format is:

**Day: Sun to Sat**

**Month: 1 to 12**

**Date: 1 to 31**

**Year: 1999 to 2099**

## Time

To set the time, highlight the “Time” field and use the <PgUp>/ <PgDn> or +/- key to set the current time.

The time format is:

**Hour: 00 to 23**

**Minute: 00 to 59**

**Second: 00 to 59**

## IDE Channel Master/Slave

The onboard PCI IDE connector provides Primary and Secondary channels for connecting up to two IDE hard disks or other IDE devices.

Press <Enter> to configure the hard disk. The selections include Auto, Manual, and None. Select ‘Manual’ to define the drive information manually. You will be asked to enter the following items.

**CYLS:** Number of cylinders

**HEAD:** Number of read/write heads

**PRECOMP:** Write precompensation

**LANDING ZONE:** Landing zone

**SECTOR:** Number of sectors

***Remarks:** The main board support two serial ATA ports and are represented in this setting as IDE Channel 0.*

## **Halt On**

This field determines whether or not the system will halt if an error is detected during power up.

No errors:

The system boot will not be halted for any error that may be detected.

All errors:

Whenever the BIOS detect a non-fatal error, the system will stop and you will be prompted.

All, But Keyboard:

The system boot will not be halted for a keyboard error; it will stop for all other errors

All, But Diskette:

The system boot will not be halted for a disk error; it will stop for all other errors.

All, But Disk/Key:

The system boot will not be halted for a key- board or disk error; it will stop for all others.

## Advanced BIOS Features

This section allows you to configure and improve your system and allows you to set up some system features according to your preference.

Phoenix - AwardBIOS CMOS Setup Utility

Advanced BIOS Features

CPU Feature	Press Enter	ITEM HELP
Hard Disk Boot Priority	Press Enter	
USB Hard Disk Boot First	Disabled	Menu Level >
Virus Warning	Disabled	
CPU Internal Cache	Enabled	
External Cache	Enabled	
Quick Power On Self Test	Enabled	
First Boot Device	Hard Disk	
Second Boot Device	CDROM	
Third Boot Device	USB-CDROM	
Boot Other Device	Enabled	
Boot Up NumLock Status	On	
Gate A20 Option	Fast	
Typematic Rate Setting	Disabled	
Typematic Rate (Chars/Sec)	6	
Typematic Delay (Msec)	250	
Security Option	Setup	
APIC Mode	Enabled	
MPS Version Control for OS	1.4	
OS Select For DRAM>64MB	Non-OS2	
HDD S.M.A.R.T. Capability	Disabled	

### CPU Feature

Press Enter to configure the settings relevant to CPU Feature.

### Hard Disk Boot Priority

With the field, there is the option to choose, aside from the hard disks connected, "Bootable add-in Cards" which refers to other external devices.

### **Virus Warning**

If this option is enabled, an alarm message will be displayed when trying to write on the boot sector or on the partition table on the disk, which is typical of the virus.

### **CPU Internal and External Cache**

Cache memory is additional memory that is faster than conventional DRAM (system memory). CPUs from 486-type on up contain internal cache memory, and most, but not all, modern PCs have additional (external) cache memory. When the CPU requests data, the system transfers the requested data from the main DRAM into cache memory, for even faster access by the CPU. These allow you to enable (speed up memory access) or disable the cache function.

### **Quick Power On Self Test**

When enabled, this field speeds up the Power On Self Test (POST) after the system is turned on. If it is set to *Enabled*, BIOS will skip some items.

### **First/Second/Third Boot Device**

These fields determine the drive that the system searches first for an operating system. The options available include *Floppy*, *LS120*, *Hard Disk*, *CDROM*, *ZIP100*, *USB-Floppy*, *USB-ZIP*, *USB-CDROM*, *LAN* and *Disable*.

### **Boot Other Device**

These fields allow the system to search for an OS from other devices other than the ones selected in the First/Second/Third Boot Device.

### **Boot Up NumLock Status**

This allows you to activate the NumLock function after you power up the system.

### **Gate A20 Option**

This field allows you to select how Gate A20 is worked. Gate A20 is a device used to address memory above 1 MB.

### **Typematic Rate Setting**

When disabled, continually holding down a key on your keyboard will generate only one instance. When enabled, you can set the two typematic controls listed next. By default, this field is set to *Disabled*.

### **Typematic Rate (Chars/Sec)**

When the typematic rate is enabled, the system registers repeated keystrokes speeds. Settings are from 6 to 30 characters per second.

### **Typematic Delay (Msec)**

When the typematic rate is enabled, this item allows you to set the time interval for displaying the first and second characters. By default, this item is set to **250msec**.

### **Security Option**

This field allows you to limit access to the System and Setup. The default value is **Setup**. When you select *System*, the system prompts for the User Password every time you boot up. When you select *Setup*, the system always boots up and prompts for the Supervisor Password only when the Setup utility is called up.

### **APIC Mode**

APIC stands for Advanced Programmable Interrupt Controller. The default setting is **Enabled**.

### **MPS Version Control for OS**

This option specifies the MPS (Multiprocessor Specification) version for your operating system. MPS version 1.4 added extended configuration tables to improve support for multiple PCI bus configurations and improve future expandability. The default setting is **1.4**.

### **OS Select for DRAM > 64MB**

This option allows the system to access greater than 64MB of DRAM memory when used with OS/2 that depends on certain BIOS calls to access memory. The default setting is **Non-OS/2**.

### **HDD S.M.A.R.T. Capability**

By default, this field is disabled.

## Advanced Chipset Features

This Setup menu controls the configuration of the chipset.

Phoenix - AwardBIOS CMOS Setup Utility

### Advanced Chipset Features

PCIe Configuration	Press Enter	ITEM HELP
IGX Configuration	Press Enter	
Memory Hole	Disabled	
System BIOS Cacheable	Disabled	
IGX Engine Clock	400	

Phoenix - AwardBIOS CMOS Setup Utility

### IGX Configuration

Internal Graphic Mode	UMA	ITEM HELP
UMA Frame Buffer Size	Auto	
Current UMA Size	0MB	

## PCIe Configuration

Upon pressing Enter, the following options and settings will appear:

GFX Overclocking: Disabled

ASPM GFX: Disabled

ASPM GPP: Disabled

ASPM NB-SB: Disabled

GFX Power Limit, Watt: 75

GPP Power Limit, Watt: 25

Debug Options: Press Enter

GFX Core Payload Size: 64byte (16/32/64byte options)

GPP Core Payload Size: 64byte (16/32/64byte options)

SB/GPP Port CFG: Auto

GFX Clock Gating: Enable/Disable

GPPSB Clock Gating: Enable/Disable

NB-SB Virtual Channel: Disable/Enable

Ports Reset Deassert Delay: 40 (20...100)

**Memory Hole At 15M-16M**

In order to improve performance, certain space in memory can be reserved for ISA cards. This memory must be mapped into the memory space below 16 MB. The choices are *Enabled* and *Disabled*.

**System BIOS Cacheable**

The setting of *Enabled* allows caching of the system BIOS ROM at F000h-FFFFh, resulting in better system performance. However, if any program writes to this memory area, a system error may result.

## Integrated Peripherals

This section sets configurations for your hard disk and other integrated peripherals. The first screen shows three main items for user to select. Once an item selected, a submenu appears. Details follow.

Phoenix - AwardBIOS CMOS Setup Utility

### Integrated Peripherals

Onboard Device	Press Enter	ITEM HELP
South OnChip PCI Device	Press Enter	Menu Level >
SuperIO Device	Press Enter	
Surroundview	Disabled	
OnChip USB Controller	Enabled	
USB EHCI Controller	Enabled	
OnChip USB KBC Controller	Enabled	
USB Mouse Support	Disabled	

Phoenix - AwardBIOS CMOS Setup Utility

### Onboard IDE Device

Onboard Lan Boot ROM	Disabled	ITEM HELP
		Menu Level >

Phoenix - AwardBIOS CMOS Setup Utility

### South OnChip PCI Device

HD Azalia Audio	Auto	ITEM HELP
OnChip SATA Controller	Enabled	
OnChip SATA Type	IDE	Menu Level >
SB600 Spread Spectrum	Enabled	

## SuperIO Device

Onboard Serial Port 1	3F8/IRQ4	ITEM HELP
Onboard Serial Port 2	2F8/IRQ3	
UART Select	Normal	
PWRON After PWR Fail	Off	

**Onboard Serial Port**

These fields allow you to select the onboard serial ports and their addresses. The default values for these ports are:

Serial Port 1: 3F8/IRQ4

Serial Port 2: 2F8/IRQ3

**UART Select**

The only setting for UART is *Normal*.

**PWRON After PWR-Fail**

This field sets the system power status whether *on* or *off* when power returns to the system from a power failure situation.

# Power Management Setup

Phoenix - AwardBIOS CMOS Setup Utility

Power Management Setup

C2 Disable/Enable	Disabled	ITEM HELP
Power Management Option	User Define	
HDD Power Down	Disabled	Menu Level >
Video Off Option	Suspend→Off	
Video Off Method	V/H SYNC+ Blank	
Soft-Off by PWR-BTTN	Instant-Off	
ACPI XSDT Table	Enabled	
HPET Support	Enabled	
RTC Alarm Resume	Disabled	
Date (of Month)	0	
Resume Time Alarm (hh:mm:ss)	0 : 0 : 0	

## C2 Disable/Enable

The default setting of this field is **Disabled**.

## Power Management Option

This field allows you to select the type of power saving management modes. There are four selections for Power Management.

Min. Power Saving: Minimum power management

Max. Power Saving: Maximum power management.

User Define: Each of the ranges is from 1 min. to 1hr. Except for HDD Power Down which ranges from 1 min. to 15 min.

## HDD Power Down

When enabled, and after the set time of system inactivity, the hard disk drive will be powered down while all other devices remain active.

## Video Off Option

This field sets the video off option. By default, video goes into suspend state and then Off.

### **Video Off Method**

This field defines the Video Off features. There are three options.

V/H SYNC + Blank: Default setting, blank the screen and turn off vertical and horizontal scanning.

DPMS: Allows BIOS to control the video display.

Blank Screen: Writes blanks to the video buffer.

### **Soft-Off by PWRBTN**

This field defines the power-off mode when using an ATX power supply. The *Instant Off* mode allows powering off immediately upon pressing the power button. In the *By Hardware mode*, the system powers off when the power button is pressed for more than four seconds or enters the suspend mode when pressed for less than 4 seconds.

### **HPET Support**

HPET, or High Precision Event Timer (formerly known as Multimedia Timer) is a hardware timer that is supported under Linux and Windows Vista. It can produce periodic interrupts at a much higher resolution than the RTC and is often used to synchronize multimedia streams, providing smooth playback and reducing the need to use other timestamp calculations such as an x86 CPU's RDTSC instruction.

## PNP/PCI Configurations

This option configures the PCI bus system. All PCI bus systems on the system use INT#, thus all installed PCI cards must be set to this value.

Phoenix - AwardBIOS CMOS Setup Utility

PnP/PCI Configurations

Reset Configuration Data	Disabled	ITEM HELP
Resources Controlled By	Auto (ESCD)	
IRQ Resources	Press Enter	IRQ Resources
PCI/VGA Palette Snoop	Disabled	
Assign IRQ For VGA	Enabled	
Assign IRQ For USB	Enabled	
PCI Latency Timer(CLK)	64	
Maximum Payload Size	4096	

### Reset Configuration Data

This field allows you to determine whether to reset the configuration data or not. The default value is **Disabled**.

### Resources Controlled by

This PnP BIOS can configure all of the boot and compatible devices with the use of a PnP operating system such as Windows 95.

### PCI/VGA Palette Snoop

Some non-standard VGA display cards may not show colors properly. This field allows you to set whether or not MPEG ISA/VESA VGA cards can work with PCI/VGA. When this field is enabled, a PCI/VGA can work with an MPEG ISA/VESA VGA card. When this field is disabled, a PCI/VGA cannot work with an MPEG ISA/VESA card.

### Assign IRQ for VGA/USB

The default value is **Enabled**

**PCI Latency**

PCI latency refers to the number of cycles that any device can hold an IRQ before it is disconnected.

**Maximum Payload Size**

The default setting of the PCI Express Maximum Payload Size is 4096.

## PC Health Status

This section shows the parameters in determining the PC Health Status. These parameters include temperatures, fan speeds and voltages.

Phoenix - AwardBIOS CMOS Setup Utility

PC Health Status

		ITEM HELP
CPU Warning Temperature	Disabled	
System Temp	45°C/113°F	
CPU Temp	45°C/113°F	Menu Level >
System Fan Speed	5400 RPM	
CPU FAN Speed	5400 RPM	
Vcore(V)	1.02 V	
+12V	12.2 V	
Vmem	1.8V	
+5V	5.13 V	
3.3V	3.29V	
VBAT (V)	3.21 V	
3VSB(V)	3.21 V	
System Smart Fan Temp	Disabled	
Fan Tolerance Value	5	
CPU Smart Fan Temp	Disabled	
Fan Tolerance Value	5	

### CPU Warning Temperature

This field allows the user to set the temperature so that when the temperature is reached, the system sounds a warning. This function can help prevent damage to the system that is caused by overheating.

### Temperatures/Voltages

These fields are the parameters of the hardware monitoring function feature of the board. The values are read-only values as monitored by the system and show the PC health status.

### 1st / 2nd Smart Fan Temperature

This field enables or disables the smart fan feature. At a certain temperature, the fan starts turning. Once the temperature drops to a certain level, it stops turning again.

### Frequency/Voltage Control

This section shows the user how to configure the processor frequency.

Phoenix - AwardBIOS CMOS Setup Utility

Frequency/Voltage Control

Spread Spectrum	Disabled	ITEM HELP
CPU Host/SRTC/ATIG	Default	Menu Level >

### Spread Spectrum

This field sets the value of the spread spectrum. The default setting is **Disabled**.  
This field is for CE testing use only.

### CPU Host/SRTC/ATIG

This field is set to **Default**.

### **Load Fail-Safe Defaults**

This option allows you to load the troubleshooting default values permanently stored in the BIOS ROM. These default settings are non-optimal and disable all high-performance features.

### **Load Optimized Defaults**

This option allows you to load the default values to your system configuration. These default settings are optimal and enable all high performance features.

### **Set Supervisor Password**

These two options set the system password. Supervisor Password sets a password that will be used to protect the system and Setup utility. User Password sets a password that will be used exclusively on the system. To specify a password, highlight the type you want and press <Enter>. The Enter Password: message prompts on the screen. Type the password, up to eight characters in length, and press <Enter>. The system confirms your password by asking you to type it again. After setting a password, the screen automatically returns to the main screen.

To disable a password, just press the <Enter> key when you are prompted to enter the password. A message will confirm the password to be disabled. Once the password is disabled, the system will boot and you can enter Setup freely.

### **Save & Exit Setup**

This option allows you to determine whether or not to accept the modifications. If you type "Y", you will quit the setup utility and save all changes into the CMOS memory. If you type "N", you will return to Setup utility.

### **Exit Without Saving**

Select this option to exit the Setup utility without saving the changes you have made in this session. Typing "Y" will quit the Setup utility without saving the modifications. Typing "N" will return you to Setup utility.

## Driver Installation

This section describes the installation procedures for software and drivers under the Windows 2000 and Windows XP. The software and drivers are included with the motherboard. If you find the items missing, please contact the vendor where you made the purchase.

### VGA Driver Installation

To install the VGA drivers, follow the steps below to proceed with the installation.

1. Insert the CD that comes with the board. Click **AMD** and click **ATI Radeon E2400 Serial Graphics Drivers**.

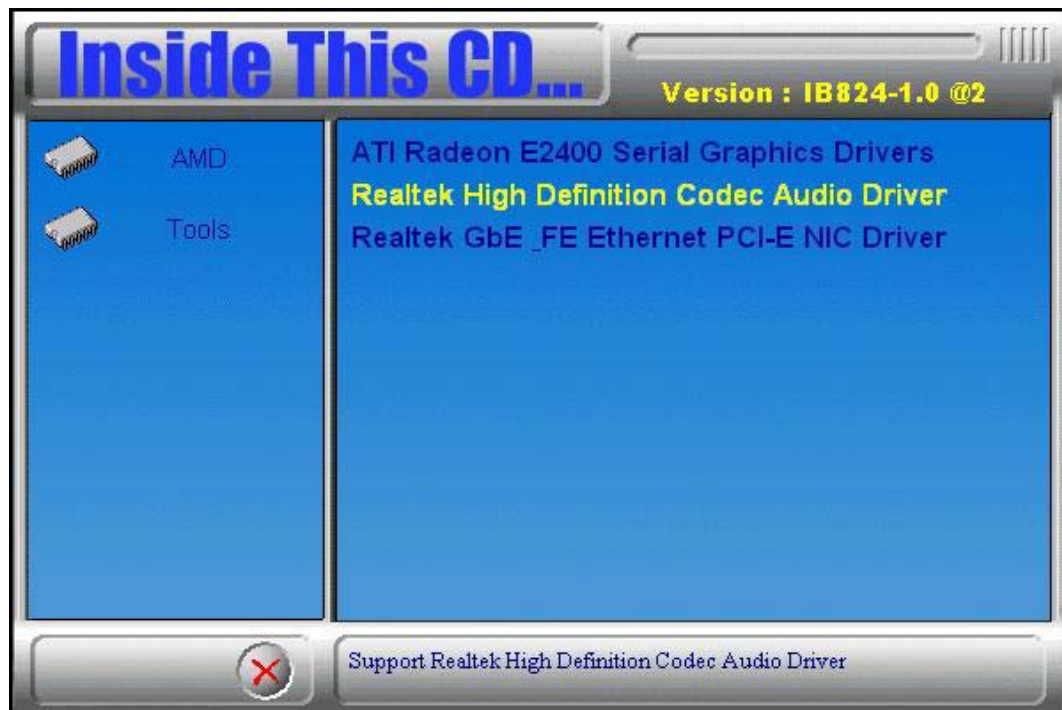

2. In the Welcome screen, click **Next** to continue. Then, in the License Agreement

screen, also click **Yes** to continue.

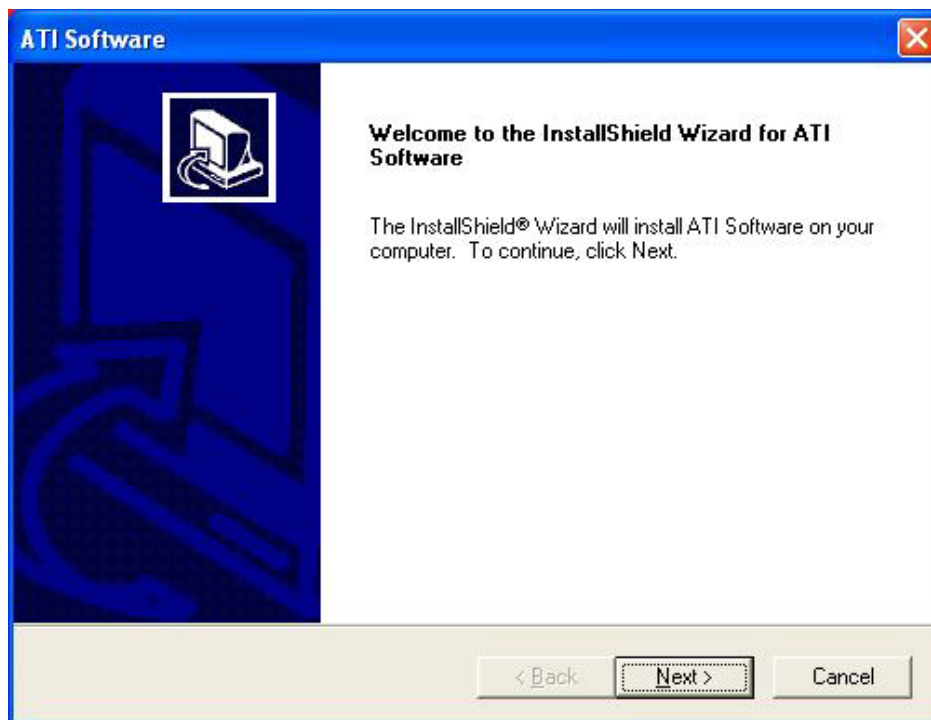

3. When the **Select Components** screen appears, click **Express: Recommended**, in selecting the component that you want to install.

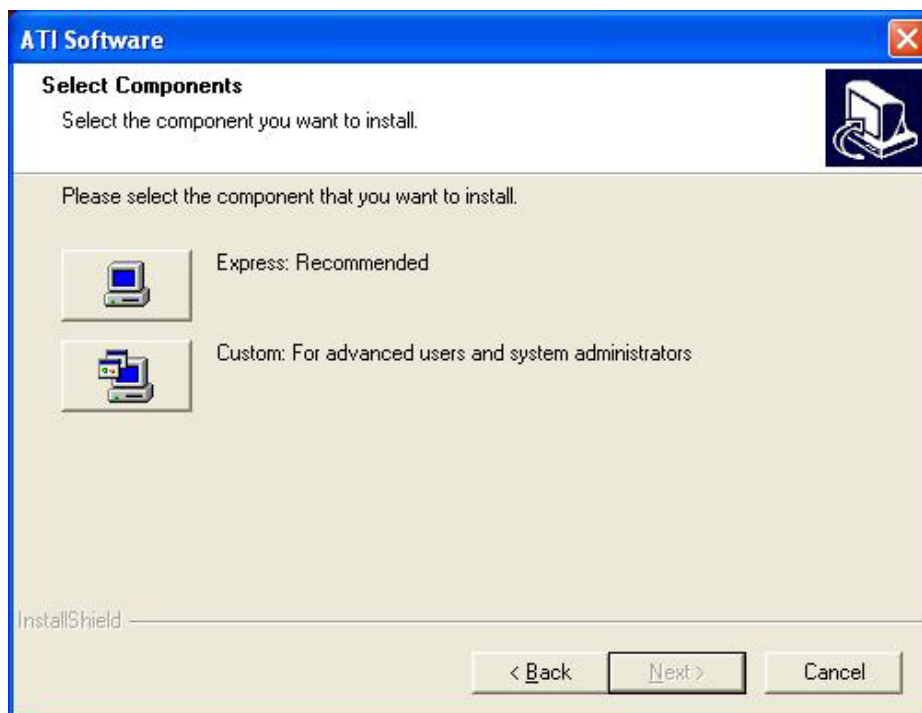

4. When the message regarding Windows Logo testing appears, click **Continue Anyway** to proceed with the driver installation.



6. Setup is now complete. Click **Finish** to restart the computer and for changes to take effect.

## Realtek High Definition Codec Audio Driver Installation

1. Insert the CD that comes with the board. Click **AMD** and click **Realtek High Definition Codec Audio Driver**.

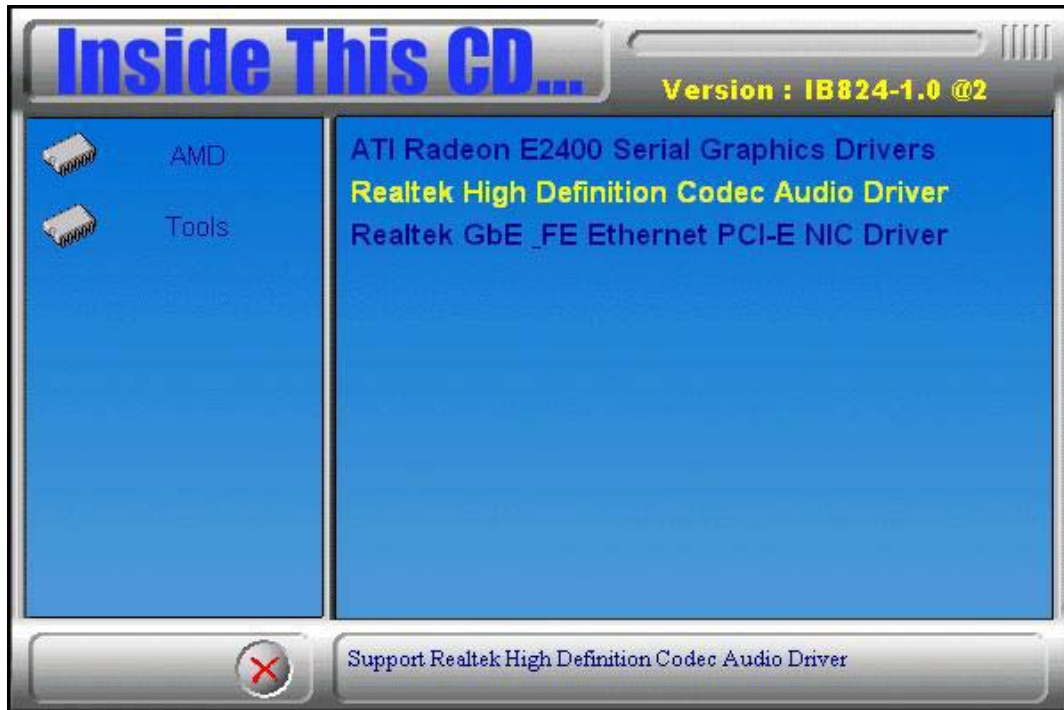

2. In the **Welcome** screen, click **Next** to continue. After the driver installation, click **Finish** on the next screen to restart the computer.

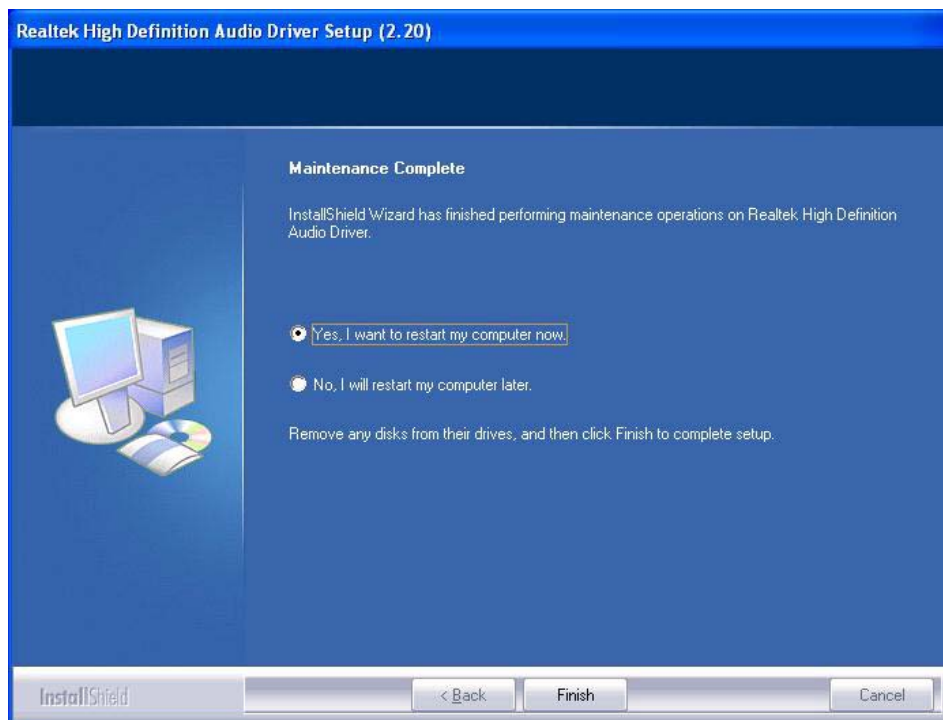

## LAN Driver Installation

1. Insert the CD that comes with the board. Click **AMD** and click **Realtek GbE\_FE Ethernet PCI-E NIC Driver**.



2. When the Welcome screen of the **InstallShield Wizard** appears, click **Next** to continue.

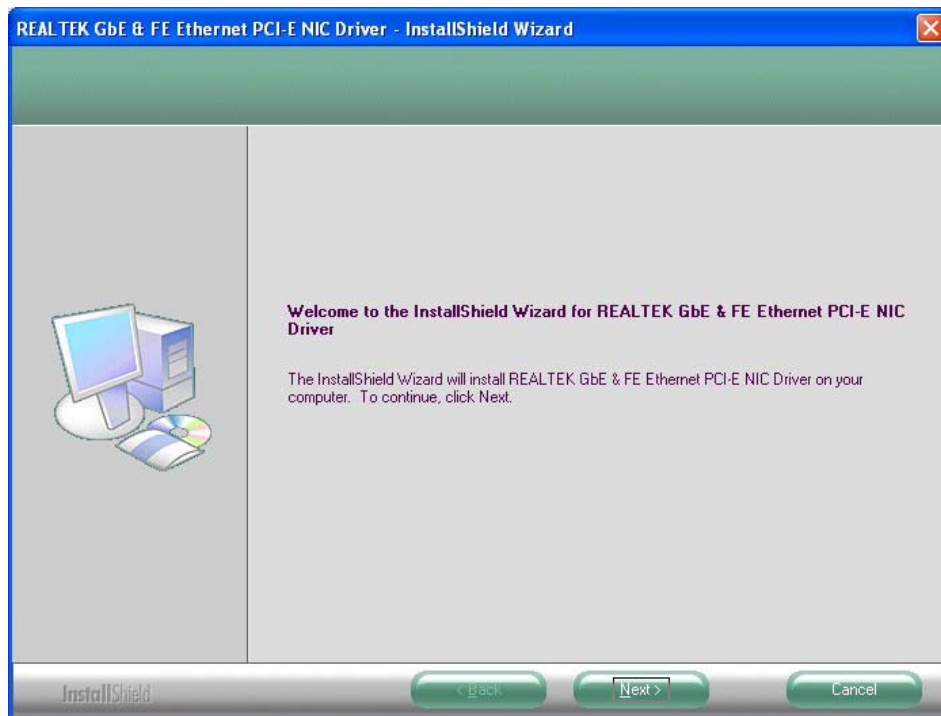

3. On the next screen, you are asked to click **Install** to begin the installation process. Now, click **Install** to proceed.

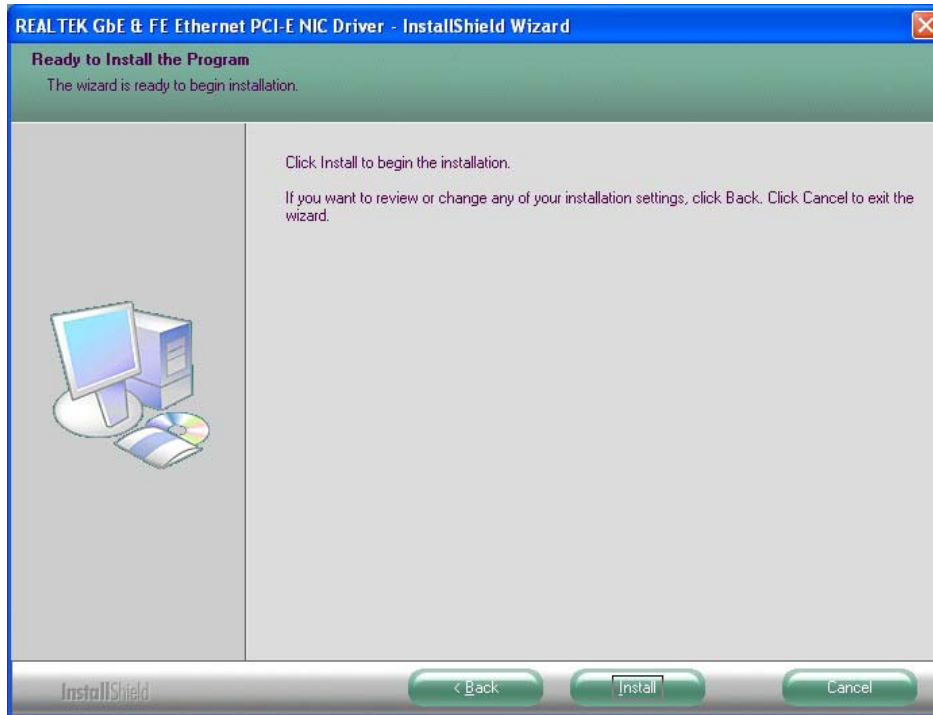

4. Installation is now complete, click **Finish** to exit the InstallShield Wizard.

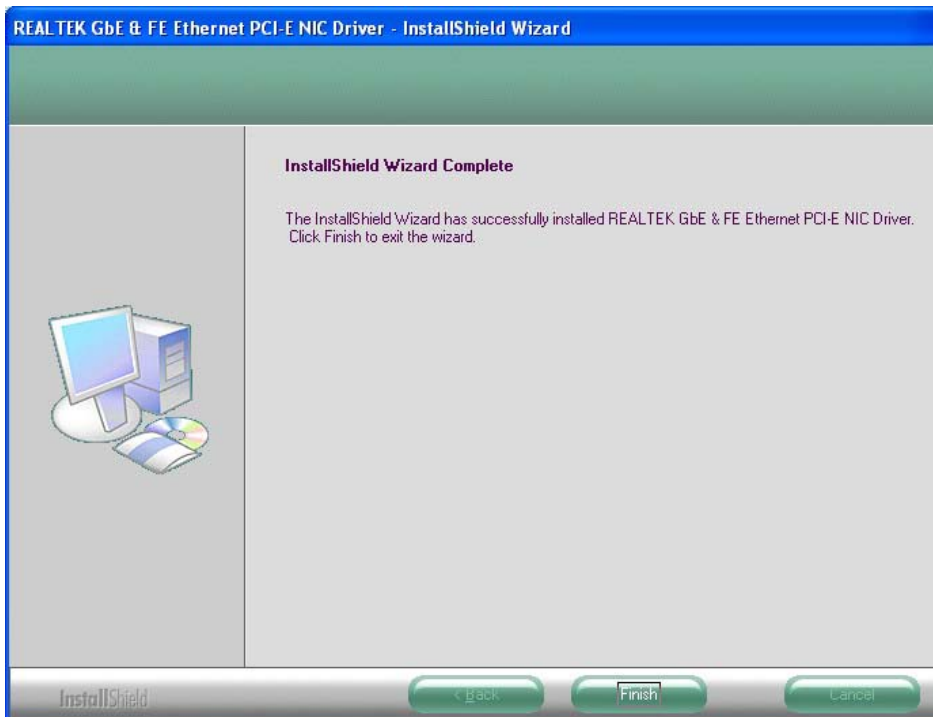

## Appendix

### I/O Port Address Map

Each peripheral device in the system is assigned a set of I/O port addresses which also becomes the identity of the device. The following table lists the I/O port addresses used.

Address	Device Description
000h - 01Fh	DMA Controller #1
020h - 03Fh	Interrupt Controller #1
040h - 05Fh	Timer
060h - 06Fh	Keyboard Controller
070h - 07Fh	Real Time Clock, NMI
080h - 09Fh	DMA Page Register
0A0h - 0BFh	Interrupt Controller #2
0C0h - 0DFh	DMA Controller #2
0F0h	Clear Math Coprocessor Busy Signal
0F1h	Reset Math Coprocessor
1F0h - 1F7h	IDE Interface
278 - 27F	Parallel Port #2(LPT2)
2F8h - 2FFh	Serial Port #2(COM2)
2B0 - 2DF	Graphics adapter Controller
378h - 3FFh	Parallel Port #1(LPT1)
360 - 36F	Network Ports
3B0 - 3BF	Monochrome & Printer adapter
3C0 - 3CF	EGA adapter
3D0 - 3DF	CGA adapter
3F0h - 3F7h	Floppy Disk Controller
3F8h - 3FFh	Serial Port #1(COM1)

## Interrupt Request Lines (IRQ)

Peripheral devices use interrupt request lines to notify CPU for the service required. The following table shows the IRQ used by the devices on board.

Level	Function
IRQ0	System Timer Output
IRQ1	Keyboard
IRQ2	Interrupt Cascade
IRQ3	Serial Port #2
IRQ4	Serial Port #1
IRQ5	Reserved
IRQ6	Floppy Disk Controller
IRQ7	Parallel Port #1
IRQ8	Real Time Clock
IRQ9	Reserved
IRQ10	Reserved
IRQ11	Reserved
IRQ12	PS/2 Mouse
IRQ13	80287
IRQ14	Primary IDE
IRQ15	Secondary IDE

## Watchdog Timer Configuration

The WDT is used to generate a variety of output signals after a user programmable count. The WDT is suitable for use in the prevention of system lock-up, such as when software becomes trapped in a deadlock. Under these sorts of circumstances, the timer will count to zero and the selected outputs will be driven. Under normal circumstance, the user will restart the WDT at regular intervals before the timer counts to zero.

### SAMPLE CODE:

```
//=====
//
// THIS CODE AND INFORMATION IS PROVIDED "AS IS" WITHOUT WARRANTY OF ANY
// KIND, EITHER EXPRESSED OR IMPLIED, INCLUDING BUT NOT LIMITED TO THE
// IMPLIED WARRANTIES OF MERCHANTABILITY AND/OR FITNESS FOR A PARTICULAR
// PURPOSE.
//
//=====
#include <stdio.h>
#include <stdlib.h>
#include "W627EHF.H"
//=====
int main (int argc, char *argv[]);
void copyright(void);
void EnableWDT(int);
void DisableWDT(void);
//=====
int main (int argc, char *argv[])
{
    unsigned char bBuf;
    unsigned char bTime;
    char **endptr;

    copyright();

    if (argc != 2)
    {
        printf(" Parameter incorrect!!\n");
        return 1;
    }

    if (Init_W627EHF() == 0)
    {
        printf(" Winbond 83627HF is not detected, program abort.\n");
        return 1;
    }
    bTime = strtol (argv[1], endptr, 10);
    printf("System will reset after %d seconds\n", bTime);

    EnableWDT(bTime);

    return 0;
}
//=====
```

```

void copyright(void)
{
    printf("\n===== Winbond 83627EHF Watch Timer Tester (AUTO DETECT) =====\n")
        "      Usage : W627E_WD reset_time\n"
        "      Ex : W627E_WD 3 => reset system after 3 second\n"
        "      W627E_WD 0 => disable watch dog timer\n");
}
//=====
void EnableWDT(int interval)
{
    unsigned char bBuf;

    bBuf = Get_W627EHF_Reg( 0x2D);
    bBuf &= (!0x01);
    Set_W627EHF_Reg( 0x2D, bBuf);           //Enable WDTO

    Set_W627EHF_LD( 0x08);                 //switch to logic device 8
    Set_W627EHF_Reg( 0x30, 0x01);         //enable timer

    bBuf = Get_W627EHF_Reg( 0xF5);
    bBuf &= (!0x08);
    Set_W627EHF_Reg( 0xF5, bBuf);         //count mode is second

    Set_W627EHF_Reg( 0xF6, interval);     //set timer
}
//=====
void DisableWDT(void)
{
    Set_W627EHF_LD(0x08);                 //switch to logic device 8
    Set_W627EHF_Reg(0xF6, 0x00);         //clear watchdog timer
    Set_W627EHF_Reg(0x30, 0x00);         //watchdog disabled
}
//=====

/=====
//
// THIS CODE AND INFORMATION IS PROVIDED "AS IS" WITHOUT WARRANTY OF ANY
// KIND, EITHER EXPRESSED OR IMPLIED, INCLUDING BUT NOT LIMITED TO THE
// IMPLIED WARRANTIES OF MERCHANTABILITY AND/OR FITNESS FOR A PARTICULAR
// PURPOSE.
//
//=====
#include "W627EHF.H"
#include <dos.h>
//=====
unsigned int W627EHF_BASE;
void Unlock_W627EHF (void);
void Lock_W627EHF (void);
//=====
unsigned int Init_W627EHF(void)
{
    unsigned int result;
    unsigned char ucDid;

    W627EHF_BASE = 0x2E;
    result = W627EHF_BASE;

    ucDid = Get_W627EHF_Reg(0x20);
    if (ucDid == 0x88)
    {    goto Init_Finish;    }

    W627EHF_BASE = 0x4E;
    result = W627EHF_BASE;
    ucDid = Get_W627EHF_Reg(0x20);
    if (ucDid == 0x88)
    {    goto Init_Finish;    }

    W627EHF_BASE = 0x00;
    result = W627EHF_BASE;

Init_Finish:
    return (result);
}
//=====
void Unlock_W627EHF (void)
{
    outportb(W627EHF_INDEX_PORT, W627EHF_UNLOCK);
    outportb(W627EHF_INDEX_PORT, W627EHF_UNLOCK);
}

```

```

//=====
void Lock_W627EHF (void)
{
    outportb(W627EHF_INDEX_PORT, W627EHF_LOCK);
}
//=====
void Set_W627EHF_LD( unsigned char LD)
{
    Unlock_W627EHF();
    outportb(W627EHF_INDEX_PORT, W627EHF_REG_LD);
    outportb(W627EHF_DATA_PORT, LD);
    Lock_W627EHF();
}

//=====
void Set_W627EHF_Reg( unsigned char REG, unsigned char DATA)
{
    Unlock_W627EHF();
    outportb(W627EHF_INDEX_PORT, REG);
    outportb(W627EHF_DATA_PORT, DATA);
    Lock_W627EHF();
}
//=====
unsigned char Get_W627EHF_Reg(unsigned char REG)
{
    unsigned char Result;
    Unlock_W627EHF();
    outportb(W627EHF_INDEX_PORT, REG);
    Result = inportb(W627EHF_DATA_PORT);
    Lock_W627EHF();
    return Result;
}
//=====

//=====
//
// THIS CODE AND INFORMATION IS PROVIDED "AS IS" WITHOUT WARRANTY OF ANY
// KIND, EITHER EXPRESSED OR IMPLIED, INCLUDING BUT NOT LIMITED TO THE
// IMPLIED WARRANTIES OF MERCHANTABILITY AND/OR FITNESS FOR A PARTICULAR
// PURPOSE.
//
//=====
#ifndef __W627EHF_H
#define __W627EHF_H        1
//=====
#define W627EHF_INDEX_PORT (W627EHF_BASE)
#define W627EHF_DATA_PORT  (W627EHF_BASE+1)
//=====
#define W627EHF_REG_LD      0x07
//=====
#define W627EHF_UNLOCK      0x87
#define W627EHF_LOCK        0xAA
//=====
unsigned int Init_W627EHF(void);
void Set_W627EHF_LD( unsigned char);
void Set_W627EHF_Reg( unsigned char, unsigned char);
unsigned char Get_W627EHF_Reg( unsigned char);
//=====
#endif        //__W627EHF_H

```